

Rossi products adhere to all UL requirements, Plenum ratings and SMACNA standards for manual dampers; and comply with NFPA 90A & 90B.

Duct fabricators often cut discs out of metal and go through a time consuming process simply to attach the disc to a bar. This involves drilling holes and using u-bolts. That was until Rossi introduced the first discs with a built-in channel for the bar to pass through. Our pre die cut and formed damper discs (blades) save significant manufacturing time and labor, assure consumer confidence in product uniformity, and provide an unparalleled system for quick assembly of dampers. And Rossi discs (or blades) are the only ones designed to be stackable. One hundred and fifty Rossi damper discs stacked together come to less than 10” high, significantly reducing inventory space.

1) DAMPER DISCS (or Blades)

MATERIAL:

Galvanized ASTM-A527 LFO G90, 20 & 22 gauge. Designed with additional reinforcement throughout the disc which effectively equals the strength of 18 gauge material. Available in 4” to 16” diameter. A 3/8” full length bar fits through the formed channel in the center of each damper blade.

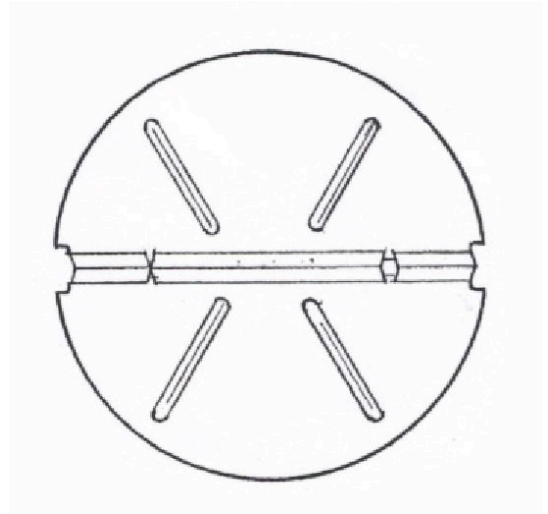

2) BARS (or Shafts)

MATERIAL: 3/8” square Aluminum bar (or shaft).



Proudly made in the USA.

www.RossiHardware.com